



MOMO C101 Wall Mount Component for MOMO Motion and Motion Plus (white)

Key Benefits

- Height Adjustable
- Suitable for one, two or a whole series of monitors
- Easy install
- Flexible modular system
- TÜV certified / 10-year guarantee

Build your ideal monitor arm The MOMO C101 Wall Mount Component is part of MOMO Motion and Motion+. Specially designed for wall mounting. The MOMO C101 is suitable for monitors up to 49". Endless possibilities Create a multi-monitor set-up with just a few components. Including both straight and angled positions. MOMO monitor arm accessories and components are installed using just one allen (hex) key, cleverly integrated into the product. So you'll always have the right tool at hand.

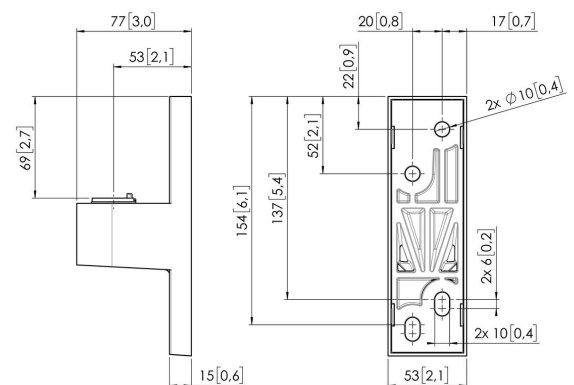



MOMO C101 Wall Mount Component for MOMO Motion and Motion Plus (white)

Specifications

Max. weight load (kg)	20
Max. weight load (Lbs)	44.09
Mounting Possibilities	On the wall
Article number (SKU)	7161011
EAN single box	8712285353925
Colour	White
TÜV certified	Yes
Guarantee	10 years

VOGEL'S HOLDING BV (©)

All rights reserved.
Subject to printing errors,
technical and price
amendments.

Date: 2024-09-10



Vogel's. For Sure.